

Präzisionsschlitten | precision slides **LINE 200 GG**

Technische Zeichnung | technical drawing

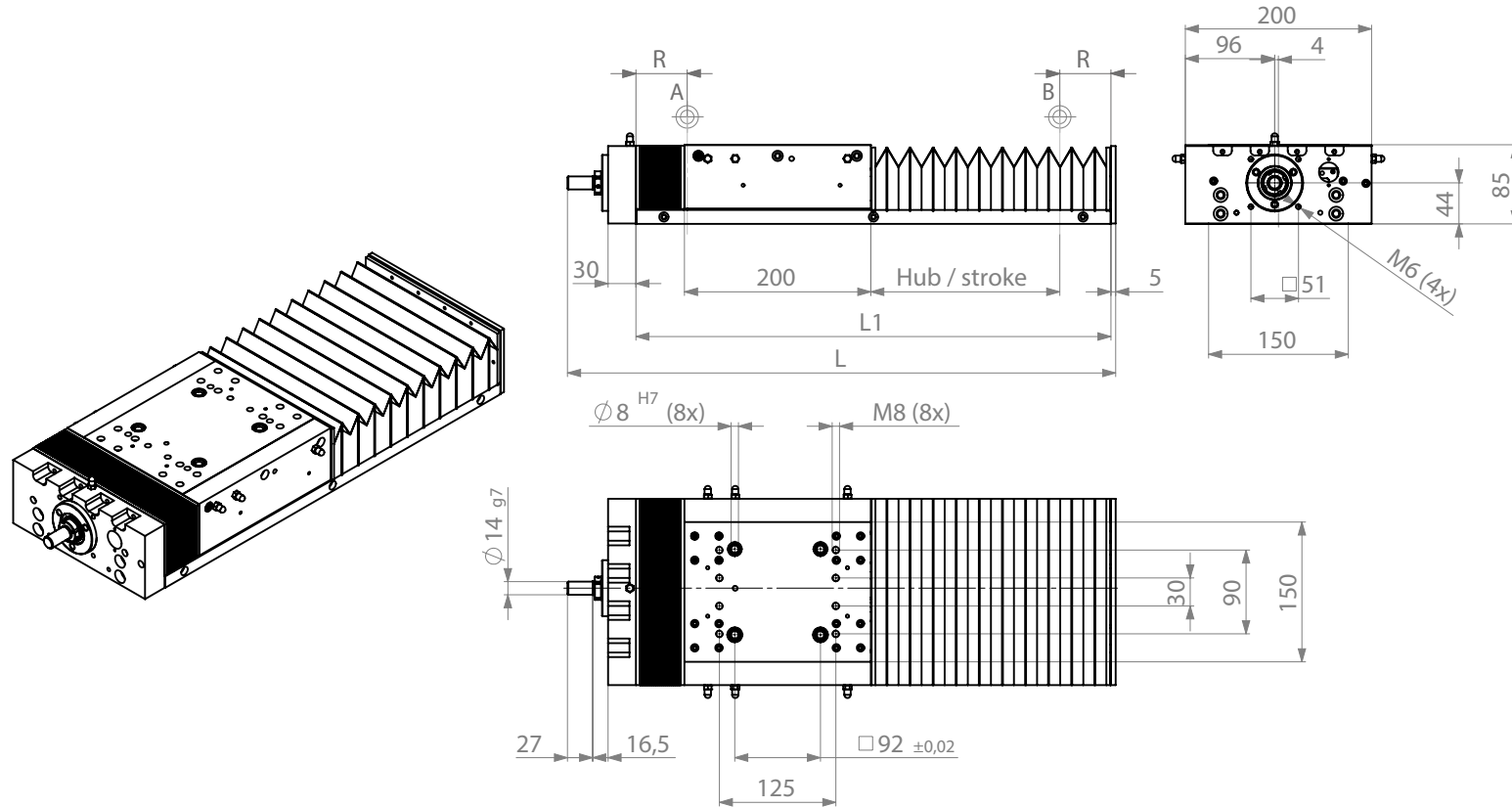

# Präzisionsschlitten | precision slides **LINE 200 GG**

## Technische Daten | technical data

Hub   stroke	L1	L	R	Gewicht   weight
190	470	548.5	40	32 kg
350	670	748.5	60	40 kg

Hub	stroke	190, 350 mm
Temperaturbereich	temperature range	0 - 60 °C
mögliche Spindelsteigung	possible spindle pitch	5 mm
Spindeldurchmesser	spindle diameter	20 mm
Wiederholgenauigkeit	repeat accuracy	+/- 0,003 mm
Ablaufgenauigkeit Gieren	process accuracy yawing	max. 0,010 / 300 mm
Ablaufgenauigkeit Nicken	process accuracy pitching	max. 0,010 / 300 mm
Spindelsteigungsfehler	spindle pitch error	max. 0,025 / 300 mm

Schlittenlänge slide length	200 mm
$C_1$	3000 N
$C_2$	3000 N
$F_{axial}$	3000 N
$M_x$	250 Nm
$M_y$	250 Nm
$M_z$	250 Nm

